

LABEL

MAGAZINE



DARE TO

denim

THE FOREVER
FASHIONABLE FABRIC

SHINE UP
YOUR HOME

GET YOUR

gold ON

FASHION // ACCESSORIES
FRAGRANCE // COSMETICS // BEAUTY

WINE AND DINE // SOCIAL SCENE

AND MUCH MORE...

WOMEN
AT WORK

GOLD COAST'S
HOSPITALITY
POWERHOUSES

BELLA Hadid

A NEW BREED OF SUPERMODEL

AUD \$6.50 NZ \$8.20

47



ABOUT LABEL MAGAZINE

LABEL represents a new industry platform showcasing the best in fashion, style, beauty, and lifestyle with brand building design and imagery.

LABEL is fast becoming one of Australia's prime fashion and lifestyle titles. This premium quality, quarterly fashion publication appeals to today's most powerful consumers.

LABEL offers a fresh approach to fashion, dining and lifestyle. LABEL attracts new names, established prestige brands, and style setters.

LABEL MARKETING

LABEL is not left on newsagency shelves. Copies are presented to people who enjoy shopping for fashion, dining, accessories, and jewellery. LABEL sponsors fashion, business, entertainment, music, and film events. The magazine is promoted via selected print and electronic media including the LABEL website – www.labelmagazine.com.au.

LABEL readers dine out, indulge in quality wines, drive beautiful cars, and live in stylish homes.

LABEL is a showcase of Australian fashion, style, and lifestyle. Since launching in 2006 LABEL has gained market position by taking a fresh approach to Australian style.

LABEL is a quarterly publication featuring fashion, dining, and the celebrity lifestyle.

DISTRIBUTION

LABEL is strategically distributed to reach high-income consumers in Queensland, New South Wales, and Victoria. LABEL is presented to diners at high-end social events and luncheons, fashion launches, wine makers' dinner, motor vehicle launches, and other major occasions designed to attract people who can afford to enjoy prestige products and services.

PROMOTION

LABEL is proactive promoting the magazine, brand, and readerships through a number of industries and events relating to fashion, business, hospitality, entertainment, music and film.

REGULAR FEATURES

- Fashion, Accessories, Jewellery
- Cosmetics, Health, Beauty, Fragrance
- Luxury goods
- Travel, Motoring, Wining and Dining
- Movies, Music, Books, Shows
- Social Scene

DEMOGRAPHICS

Female	76%
Male	24%

SOCIOECONOMIC

AB	34%
C	31%
D	21%
E	14%

AGE GROUP

14-17	4.3%
18-24	19%
25-34	34%
35-49	29%
50+	13.7%

LIVING ARRANGEMENTS

Renting	51%
Own Property	34%

INCOME

Under 20,000	3.9%
20,000 – 29,000	14%
30,000 – 39,000	19%
40,000 – 49,000	19.1%
50,000 – 60,000	24.7%
60,000+ 1	9.3%

BUYING POWER

(AVERAGE SPEND PER MONTH)	
Clothing	\$1800
Cosmetics	\$190

EDITORIAL



A NEW STANDARD OF LUXURY IN Kuala Lumpur

The Sofitel Kuala Lumpur is a new landmark hotel in the heart of the city. It is a 45-story skyscraper with 450 rooms, 10 restaurants, 10 bars, and a spa. The hotel is a perfect blend of modern luxury and traditional Malaysian architecture. The hotel is a perfect blend of modern luxury and traditional Malaysian architecture. The hotel is a perfect blend of modern luxury and traditional Malaysian architecture.

ADVERT

omilon

INTELLIGENT COMPLETE BODY TRAINING IN JUST 17.5 MINUTES

INSERT CARD & PRESS START & WORK OUT & LOG IN TO CHECK YOUR TRAINING PERFORMANCE

SIMPLE. SAFE. EFFECTIVE.

we CARE about YOU

MARINAMIRAGE

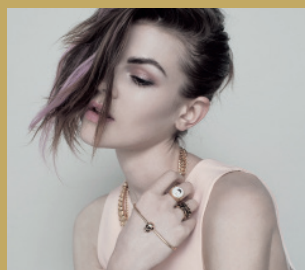

ADVERTISING RATES

	Casual
Full page colour	\$4,500
Half page colour	\$3,500
Third page colour	\$2,500
DPS	\$6,000
Back cover	\$7,000
Inside FC or Inside BC	\$6,000

Multiple booking rates on application. Run-ons available.

ADVERTISING DEADLINES

Publication	Booking Deadline	Material Deadline
1 December 2017	1 November 2017	8 November 2017
1 March 2018	1 February 2018	8 February 2018
1 June 2018	1 May 2018	8 May 2018
1 September 2018	1 August 2018	8 August 2018

PAYMENT TERMS

10 per cent GST applies on all prices.

Total cost per issue to be paid as follows:

- On contract one third total cost.
- With proof approval one third total cost.
- On publication one third total.

DESIGN AND ARTWORK ENQUIRIES

E art@labelmagazine.com.au

ARTWORK

Charges/Proofs and Specifications

- Photography, artwork, copy writing, advertising design and layout fees on application.
- Proof supplied in PDF format.
- Advertisers are responsible accuracy on proofing.
- Changes and approvals required by email or fax.
- Complete material supplied as press quality pdf (300 dpi)
- Document setup to final trim size (see page specifications)

CANCELLATIONS

- Written cancellations accepted seven days prior to booking deadline. Cancellations after the booking deadline will be charged at full rate.

SALES AND ADVERTISING ENQUIRIES

Elizabeth Austin 0431 015 666

E elizabeth@labelmagazine.com.au

T 07 5591 7231 F 07 5538 5964

PO Box 8875 GCMC QLD 9726

EDITORIAL

BEAUTY

Dessata DESIRES

Local chats with Dessata Australia brand manager Nicki Fitzpatrick about the best way to de-stress our tissues this Spring.

- 1 What's Dessata and what does the brand stand for? Nicki: Dessata is a natural, organic, and cruelty-free brand that focuses on skin health and wellness. We use only the highest quality ingredients and are committed to ethical sourcing.
- 2 How does the brand manage other skin care products? We offer a range of products including cleansers, toners, serums, and moisturizers. Our products are designed to work together to provide a complete skin care routine.
- 3 The new Dessata facial oil. It's a great skin care product. Can you tell us more about it? The new facial oil is a lightweight, non-greasy formula that provides deep hydration and nourishment. It's perfect for all skin types and can be used as a pre-moisturizer or a finishing oil.
- 4 Skincare is not a luxury for all ages. Why is it important to use a skincare from young age? Skincare is essential for everyone, regardless of age. It helps to protect the skin from environmental damage and keeps it hydrated and healthy.
- 5 What are the ingredients used in your products? We use natural, organic ingredients such as aloe vera, jojoba oil, and essential oils. We are committed to transparency and ethical sourcing.
- 6 What other products or services can you offer? We offer a range of products including body care, hair care, and bath products. We also have a subscription service for our products.

38

FRAGRANCE

FRAGRANCE

High-End, the best fragrance. Intensity is the key to the... High-End, the best fragrance. Intensity is the key to the... High-End, the best fragrance. Intensity is the key to the...

39

ADVERT

BLISS BY
Sonia Stradotto
COUTURE

Sonia Stradotto Couture is for women who value quality, individuality and unique styles. For 27 years we have had the privilege of being a part of your special occasions. Today and for evermore, we give you every step of the way for every special moment of your life. Our brand carries great style, color, texture, movement, freedom of fit, fabric and glamour. Living your dreams is our ultimate purpose. Celebrate for special occasions, anniversaries, celebration and corporate companies.

CONTACT US TODAY

PHONE: 07 5591 7231

PHONE: 07 5538 5964

EMAIL: elizabeth@labelmagazine.com.au

WEBSITE: www.soniastradottocouture.com

ELIXIR OF YOUTH

EXPERIENCE • RESULTS • SATISFACTION

Fraxel® offers an effective, safe and non-invasive approach to laser skin resurfacing, working to stimulate collagen renewal and reduce aged skin cells with new, bring fresh, healthy, glowing skin back to the surface.

Fraxel® is one of the original fractional laser treatments available and is still the one to choose when you want your natural radiance to return.

BENEFITS INCLUDE:

- Treatment of pigmentation and scarring
- Improved skin tone and texture
- Reduced fine lines and wrinkles
- Smoother, younger looking skin

Australian Skin Clinics Ashmore is the only clinic on the Gold Coast with the latest Fraxel® Dual 1550/1927 laser technology. Offering two treatment modes to effectively target both the surface of the skin and the deeper layers below for smoother looking skin.

To take advantage of our complimentary consultation call today 07 5509 0081

Australian Skin Clinics
Laser & Rejuvenation Experts

7/151 Coleridge Street, Ashmore QLD 4214 • www.usclin.com



PAGE SPECIFICATIONS

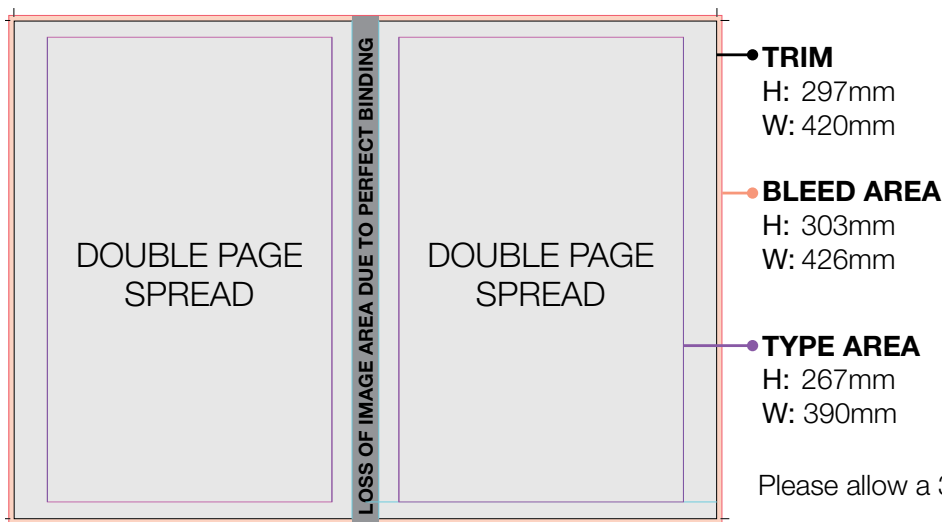
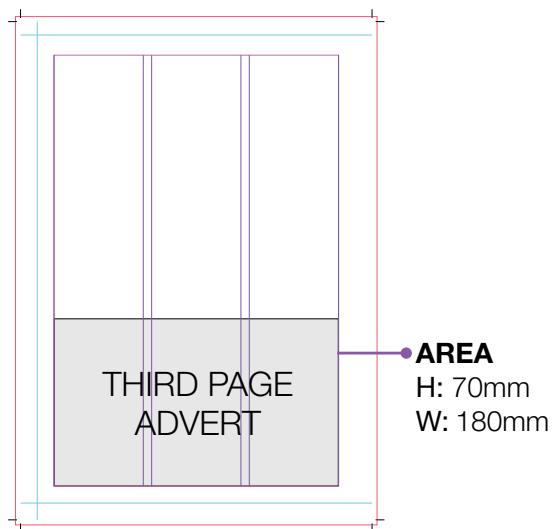
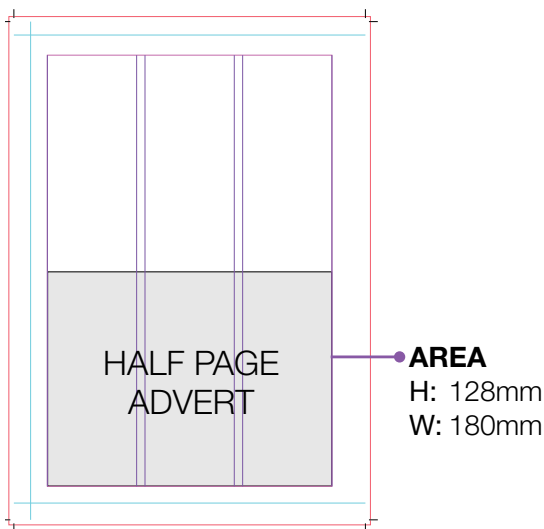
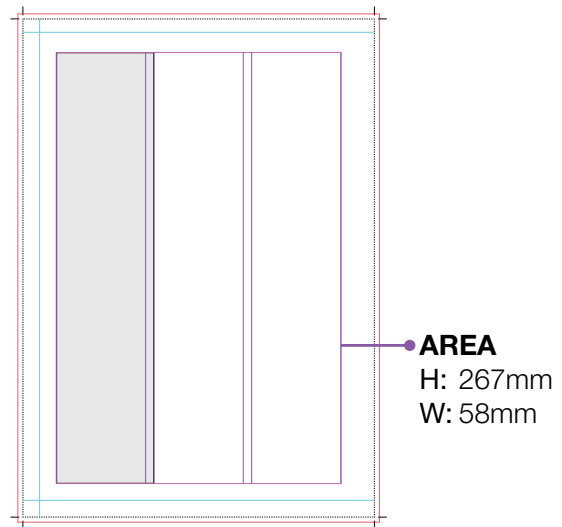
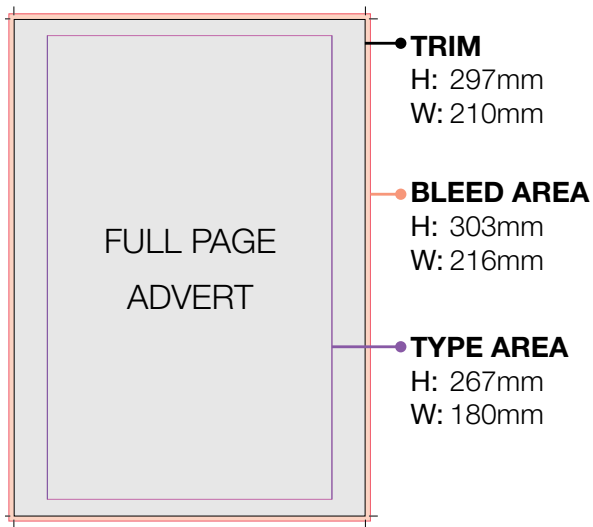

Please allow a 30mm safety gutter in centre of spread